

For use in helping to provide resettable overcurrent protection for bus and truck wire harnesses utilizing 24V electrical systems, PolySwitch AHEF devices are rated for a maximum operating temperature of 125°C, permitting their use in both passenger and engine compartments. The product family of seven devices includes hold-current ratings from 0.50A to 10A, with a maximum fault-current rating of 100A, and a maximum operating voltage rating of 32V for all devices. The radial-leaded devices are tested to the AECQ200 standard and are RoHS and ELV compliant.

Next-generation wire harnesses generally utilize a hierarchal structure with main power trunks dividing into smaller branches and containing overcurrent protection at each node. The PolySwitch AHEF devices facilitate new harness architectures by providing resettable protection, which allows placement in inaccessible locations, such as under the seat or in door panels.

PolySwitch AHEF devices give designers the ability to locate junction boxes close to their intended electronics, whether in the passenger compartment to help protect BCUs (Body Control Units) or in the engine compartment to help protect HVAC controls.



Benefits:

- Resettable functionality permits placement in inaccessible locations
- High temperature rating permits use in harsh underhood applications
- Worldwide team dedicated to supporting automotive design applications

Features:

- Wide range of form factor and termination methods
- Products meet all applicable automotive industry standards
- Devices compatible with high-volume electronics assembly

Applications:

- 24V battery automotive applications
- Automobile harnesses
- Junction boxes
- Electronic control modules
- Automotive actuators
- Medium-sized DC motors

Thermal Derating [Hold Current (A) at Ambient Temperature (°C)]

Part Number	Maximum Ambient Temperature										
	-40°C	-20°C	0°C	20°C	25°C	40°C	50°C	60°C	70°C	85°C	125°C
AHEF (High Temperature) 32V—Radial-leaded											
NEW AHEF050	0.7	0.6	0.6	0.5	0.5	0.4	0.4	0.4	0.3	0.3	0.1
NEW AHEF070	1.0	0.9	0.8	0.7	0.7	0.6	0.6	0.5	0.5	0.4	0.2
NEW AHEF100	1.4	1.2	1.1	1.0	1.0	0.9	0.8	0.7	0.7	0.6	0.2
NEW AHEF300	4.1	3.8	3.4	3.1	3.0	2.7	2.4	2.2	2.0	1.7	0.6
NEW AHEF500	6.8	6.3	5.7	5.2	5.0	4.5	4.1	3.7	3.3	2.8	1
NEW AHEF750	10.2	9.4	8.6	7.7	7.5	6.7	6.1	5.6	5.0	4.1	1.5
NEW AHEF1000	13.6	12.5	11.4	10.3	10.0	8.9	8.1	7.4	6.6	5.5	2

Thermal Derating Curves

AHEF

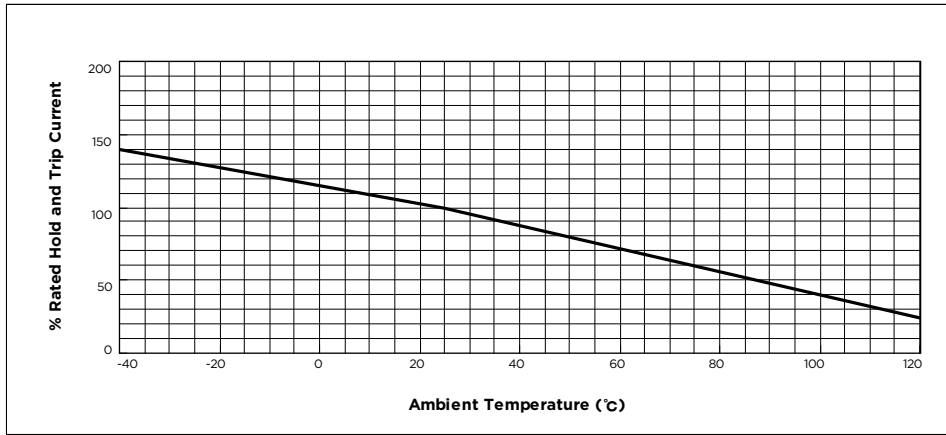

Electrical Characteristics

Part Number	IH(A)@ R _{1Max}	IH(A)@ R _{aMax}	IT (A)	V _{Max} (V _{DC})	I _{Max} (A)	P _{D TYP} (W)	Max. Time-to-trip (A) (S)	R _{Min} (Ω)	R _{1Max} (Ω)	R _{aMax} (Ω)
AHEF										
32V - Radial-leaded (High Temperature)										
NEW AHEF 050	0.5	0.5	1.0	32	100	0.9	2.5 3.0	0.3500	1.100	1.100
NEW AHEF 070	0.7	0.7	1.4	32	100	0.9	3.5 3.2	0.2300	0.800	0.800
NEW AHEF 100	1.0	1.0	1.9	32	100	1.4	5.0 6.2	0.1500	0.430	0.430
NEW AHEF 300	3.0	3.0	6.0	32	100	3.2	15.0 5.0	0.0350	0.110	0.110
NEW AHEF 500	5.0	5.0	10.0	32	100	5.3	25.0 9.0	0.0150	0.040	0.040
NEW AHEF 750	7.5	7.5	15.0	32	100	6.5	37.5 13.0	0.0074	0.023	0.023
NEW AHEF 1000	10.0	10.0	20.0	32	100	7.0	50.0 15.0	0.0060	0.016	0.016

Notes :

- I_H = Hold current: maximum current device will pass without interruption in 25°C still air, unless otherwise specified.
- I_T = Trip current: minimum current that will switch the device from low resistance to high resistance in 25°C still air, unless otherwise specified.
- V_{MAX} = Maximum voltage device can withstand without damage at rated current.
- I_{MAX} = Maximum fault current device can withstand without damage at rated voltage.
- P_D = Power dissipated from device when in the tripped state in 25°C still air, unless otherwise specified.
- R_{1MAX} = Maximum resistance of device when measured one hour post trip at 25°C unless otherwise specified.
- R_{aMAX} = Maximum functional resistance of device after being subjected to the stresses described in PS400 at 25°C, unless otherwise specified.
- R_{MIN} = Minimum resistance of device as supplied at 25°C, unless otherwise specified.

Dimension Figures

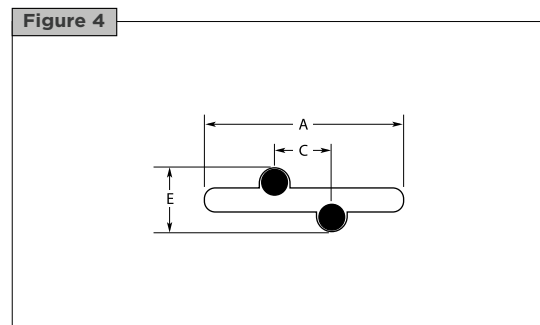
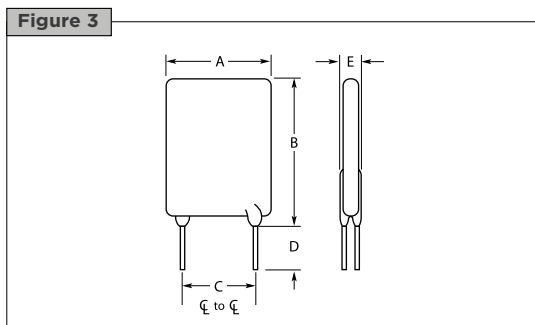
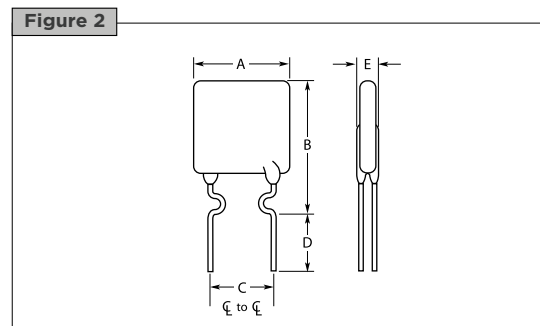
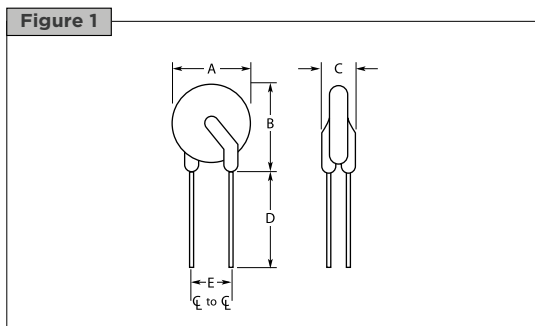

Dimensions in Millimeters (Inches)

Part Number	Dimension A		Dimension B		Dimension C		Dimension D		Dimension E		Figure
	Min.	Max.	Min.	Max.	Min.	Max.	Min.	Max.	Min.	Max.	
AHEF											
32V - Radial-leaded (High Temperature)											
NEW AHEF050	—	7.4 (0.29)	—	12.7 (0.50)	4.3 (0.17)	5.8 (0.23)	7.6 (0.30)	—	—	3.3 (0.13)	1, 4
NEW AHEF070	—	6.9 (0.27)	—	10.8 (0.43)	4.3 (0.17)	5.8 (0.23)	7.6 (0.30)	—	—	3.0 (0.12)	2, 4
NEW AHEF100	—	9.7 (0.38)	—	13.6 (0.54)	4.3 (0.17)	5.8 (0.23)	7.6 (0.30)	—	—	3.0 (0.12)	1, 4
NEW AHEF300	—	10.2 (0.40)	—	15.5 (0.61)	4.32 (0.17)	5.84 (0.23)	7.6 (0.30)	—	—	3.8 (0.15)	3, 4
NEW AHEF500	—	14.0 (0.55)	—	24.1 (0.95)	4.3 (0.17)	5.8 (0.23)	11.5 (0.45)	—	—	3.8 (0.15)	3, 4
NEW AHEF750	—	21.1 (0.83)	—	24.9 (0.98)	9.4 (0.37)	10.9 (0.43)	7.6 (0.30)	—	—	3.8 (0.15)	3, 4
NEW AHEF1000	—	23.5 (0.93)	—	27.9 (1.10)	9.4 (0.37)	10.9 (0.43)	7.6 (0.30)	—	—	4.0 (0.16)	3, 4

Typical Time-to-trip at 25°C

AHEF

- A = AHEF050
- B = AHEF070
- C = AHEF100
- D = AHEF300
- E = AHEF500
- F = AHEF750
- G = AHEF1000

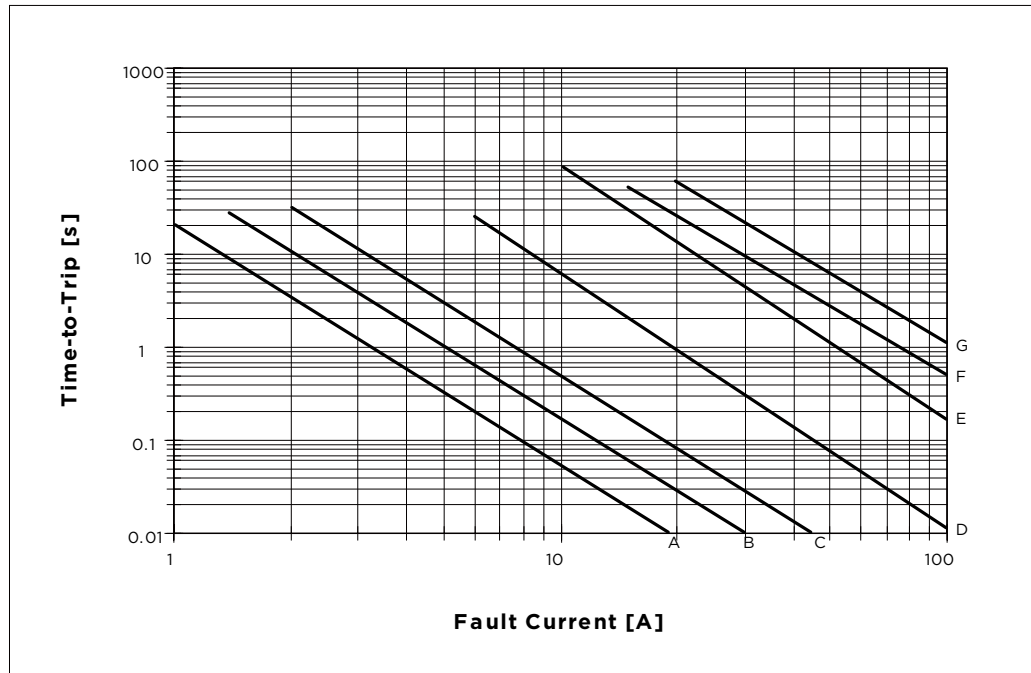

Physical Characteristics and Environmental Specifications

AHEF Physical Characteristics

Lead material	AHEF050 to AHEF100: Tin-plated Copper Clad Steel, 0.205mm ² (24AWG), ø0.51mm/0.020in AHEF300 to AHEF750: Tin-plated Copper 0.52mm ² (20 AWG), ø0.81mm/0.032in AHEF1000: Tin-plated Copper 0.82mm ² (18AWG), ø1.0mm/0.04in
Soldering characteristics	Solderability per ANSI/J-STD 002 Category 3
Solder heat withstand	per IEC 68-2-20, Test Tb, Method 1A, Condition B; can withstand 10 seconds at 260°C ± 5°C
Insulating material	Cured, flame-retardant epoxy polymer; meets UL 94V-0 requirements

Note: Devices are not designed to be placed through a reflow process.

AHEF Physical Characteristics

Test	Conditions	Resistance Change
Passive aging	70°C, 1000 hours	± 5%
	85°C, 1000 hours	± 5%
Humidity aging	85°C, 85% RH, 1000 hours	± 5%
Thermal shock	125°C, -40°C (10 times)	± 5%
Solvent resistance	MIL-STD-202, Method 215F	No change

Packaging and Marking Information

	Part Number	Bag Quantity	Tape & Reel Quantity	Ammo Quantity	Standard Package Quantity	Part Marking
NEW	AHEF050	500	—	—	10,000	EF0.5
NEW	AHEF070	500	—	—	10,000	EF0.7
NEW	AHEF100	500	—	—	10,000	EF1.0
NEW	AHEF300	500	—	—	10,000	EF3
NEW	AHEF500	250	—	—	5,000	EF5
NEW	AHEF750	250	—	—	5,000	EF7.5
NEW	AHEF1000	250	—	—	5,000	EF10

Raychem Circuit Protection Products

308 Constitution Drive, Building H Tel : (800) 227-7040, (650) 361-6900
Menlo Park, CA USA 94025-1164 Fax : (650) 361-4600

www.circuitprotection.com
www.circuitprotection.com.hk (Chinese)
www.tycoelectronics.com/japan/raychem (Japanese)

Raychem, PolySwitch, TE Logo and Tyco Electronics are trademarks. All other trademarks are trademarks of their respective owners. All information, including illustrations, is believed to be reliable. Users, however, should independently evaluate the suitability of each product for their application. Tyco Electronics makes no warranties as to the accuracy or completeness of the information, and disclaims any liability regarding its use. Tyco Electronics' only obligations are those in Tyco Electronics' Standard Terms and Conditions of Sale for this product, and in no case will Tyco Electronics be liable for any incidental, indirect, or consequential damages arising from the sale, resale, use or misuse of the product. Specifications are subject to change without notice. In addition, Tyco Electronics reserves the right to make changes—without notification to Buyer—to materials or processing that do not affect compliance with any applicable specification.

© 2008 Tyco Electronics Corporation. All rights reserved.

 **Tyco Electronics**
Our commitment. Your advantage.